

THERMOCORE PANEL SYSTEMS

INSTALLATION MANUAL WITH ARCHITECTURAL DETAILS

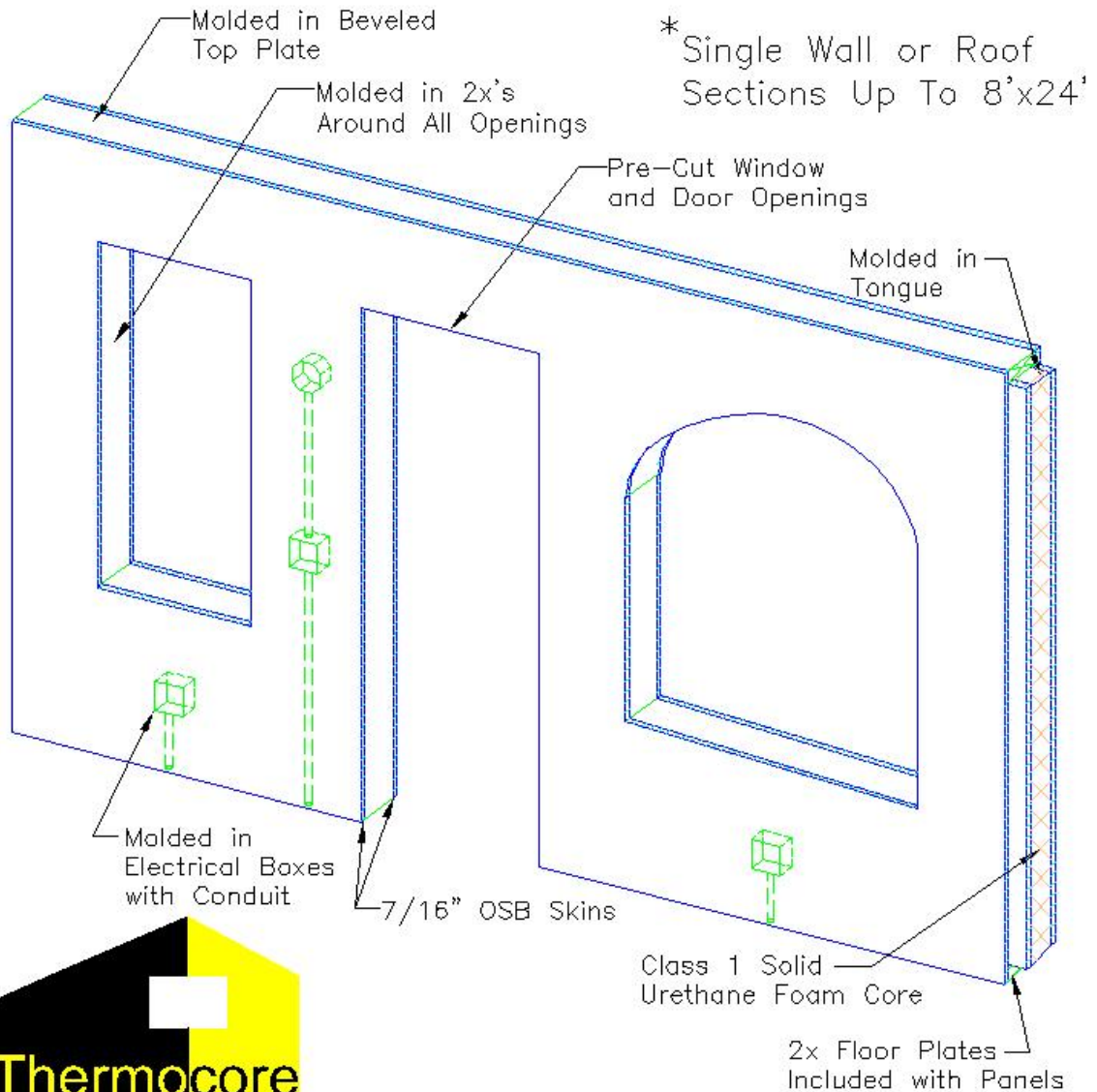

1801 HANSEL PARKWAY
MOORESVILLE, IN. 46158

Ph. (317) 831-8888
Fax (317) 831-8889

www.Thermocore.com
salesinfo@thermocore.com

TABLE OF CONTENTS

THERMOCORE PANEL SYSTEMS INTRODUCTION.....	3-6
STANDARD PANEL CONFIGURATION.....	7
THERMOCORE ROOF GUIDELINES.....	8
GENERAL PANEL GUIDELINES	9-10
STRUCTURAL THEORY.....	11
FIGURES 2A & 2B: LOADING DETAILS	12
OFFLOADING AND HANDLING PANELS ON SITE.....	13
FIGURE 3: OFF-LOADING WRAPPED PANEL BUNDLES.....	14
GENERAL INSTALLATION.....	15
PANEL CONNECTIONS AND SEALING.....	16
WALL PANEL INSTALLATION.....	17-18
ROOF PANEL INSTALLATION.....	19
DOOR AND WINDOW OPENINGS.....	20
WIRING INSTALLATION.....	21
PLUMBING INSTALLATION.....	22
HEATING AND AIR INSTALLATION.....	23
SPECIAL CUTTING AND ROUTING PANELS.....	24
FINISHING.....	25
CLOSING.....	26
ARCHITECTURAL DETAIL DRAWINGS.....	27

THERMOCORE PANEL SYSTEMS INTRODUCTION

PANEL DESCRIPTIONS

4" PANEL 7/16" OSB/OSB skins (interior/exterior). OSB is exterior grade. 3-1/8" polyurethane core R-24 with a Class 1/A fire rating. Used for both timber frame walls and first and second floor structural walls (non-timber frame) up to 9' in height.

4-1/2" PANEL 7/16" OSB/OSB skins (interior/exterior). OSB is exterior grade. 3-1/2" polyurethane core R-28 with a Class 1/A fire rating. Used for structural walls over 9' in height.

6-1/2" PANEL 7/16" OSB/OSB skins (interior/exterior). OSB is exterior exposure rated. 5-1/2" polyurethane core R-40 with a Class 1/A fire rating. Used for roofs over timber frames and as a structural roof.*

*consult span tables

PANEL COMPONENTS

Each Thermocore Panel is composed of the following materials:

OSB: Thermocore uses either APA or Teco approved OSB, rated exposure 1. Thickness is 7/16" for both skins and the OSB has a rating of PS-2

FOAM: Thermocore uses a Class 1/A polyurethane foam with a minimum density of 2.3lbs. The foam has a fire retardant incorporated with in and has the highest fire rating given to a residential building product. The foam will not support mold growth and is its own vapor barrier. The foam has no nutritional value to insects or rodents. Polyurethane foam is commonly used in building as well as other household products. Polyurethane foam is stronger and more energy efficient than other foams available on the market.

Electrical Boxes: Thermocore incorporates into its panel 4"x4" x2-3/8", double gang, plastic electrical boxes rated by U/L. Each box has six "knock outs" for conduit.

Electrical Conduit: Thermocore incorporates 3/4" I.D. conduit in its panel system. The conduit is electrical non-metallic schedule 40 PVC and is rated for a two and three hour fire wall assembly.

Dimensional Lumber: Any dimensional lumber incorporated with in the panels is # 2 or better SPF lumber unless other wise specified. Additional engineered lumber can be installed within a panel when specified.

Fasteners: Thermocore utilizes 1 1/2" 16ga. wide crown staples in the assembly of its panel system. 16 penny nails can be substituted upon request.

TECHNICAL NOTES

SHINGLES-Thermocore is pleased to announce that Elk Corporation fully warranties their shingles placed directly on Thermocore's Panels with out venting. Thermocore recommends that you specify Elk shingles for your roofing application.

FASTENER STRENGTH-Thermocore has conducted pullout strength of various fasteners into the 7/16" OSB skin of the Thermocore Panel. The following guidelines should be followed when specifying fasteners:

	PULL-OUT	SHEAR
#6 Deck Screw	125lbs.	180lbs.
#8 Deck Screw	135lbs.	115lbs.
#10 Deck Screw	145lbs.	115lbs.

The number presented here are guidelines. Please consult Thermocore or an engineer for special fastening needs.

FASTENING HARDIE PLANK SIDING-Hardie Plank siding can be fastened to panels by two methods. The first is to face nail the boards according to the manufacturers recommendation. The second is to fasten the boards with the #8x1-5/8" stainless steel screws, 8" O.C..

INTRODUCTION

The use of foam core panel technology in the construction of homes will prove to be one of the most significant contributions of the twentieth century. Developed in the 1950's and more widely adapted for residential construction in the 1970's, this building system provides both superior insulation and structural integrity. These stress skin or structural insulated panels have proved to be an excellent wall and roof system for conventional homes and an ideal enclosure system for post and beam (timber-framed) construction.

With the introduction of Thermocore's pre-configured panel, the next evolutionary step in the progression on this industry has occurred. Thermocore begins by producing CAD drawings of each panel showing exact sizes, edge geometry, door and window block placements, and electric box and conduit mapping. Next, both the interior and exterior skins are pre-configured in accordance with your architectural drawings before placement in our modular form system. Thus, each panel is pre-shaped and custom configured for a specific location on the home. Our manufacturing process does not produce any foam scrap, on-site panel waste is largely eliminated, and our clients only pay for the panel area actually used.

Figure 1 illustrates a set of pre-configured wall panels complete with molded-in-place window openings, corner board, electrical boxes connected with conduit, and tongue and groove joint. A cross-section shows the typical tongue and groove edges used at most panel connections. Note the flexible foam gasket which is compressed when the joint is pulled together. Conduit can also be connected between panel joints.

Currently, Thermocore offers panels with three thicknesses (4", 4-1/2", 6-1/2") at widths up to 8 feet and lengths up to 24 feet. Each panel consists of a polyurethane foam core sandwiched between two 7/16" OSB skins. For roof applications Thermocore's roof panels require support every 10'. Please consult Thermocore for specifics.

This guide covers basic Thermocore panel handling and installation procedures. Further information or answers to specific questions can be obtained by Thermocore directly.



FIGURE 1

STANDARD PANEL CONFIGURATION

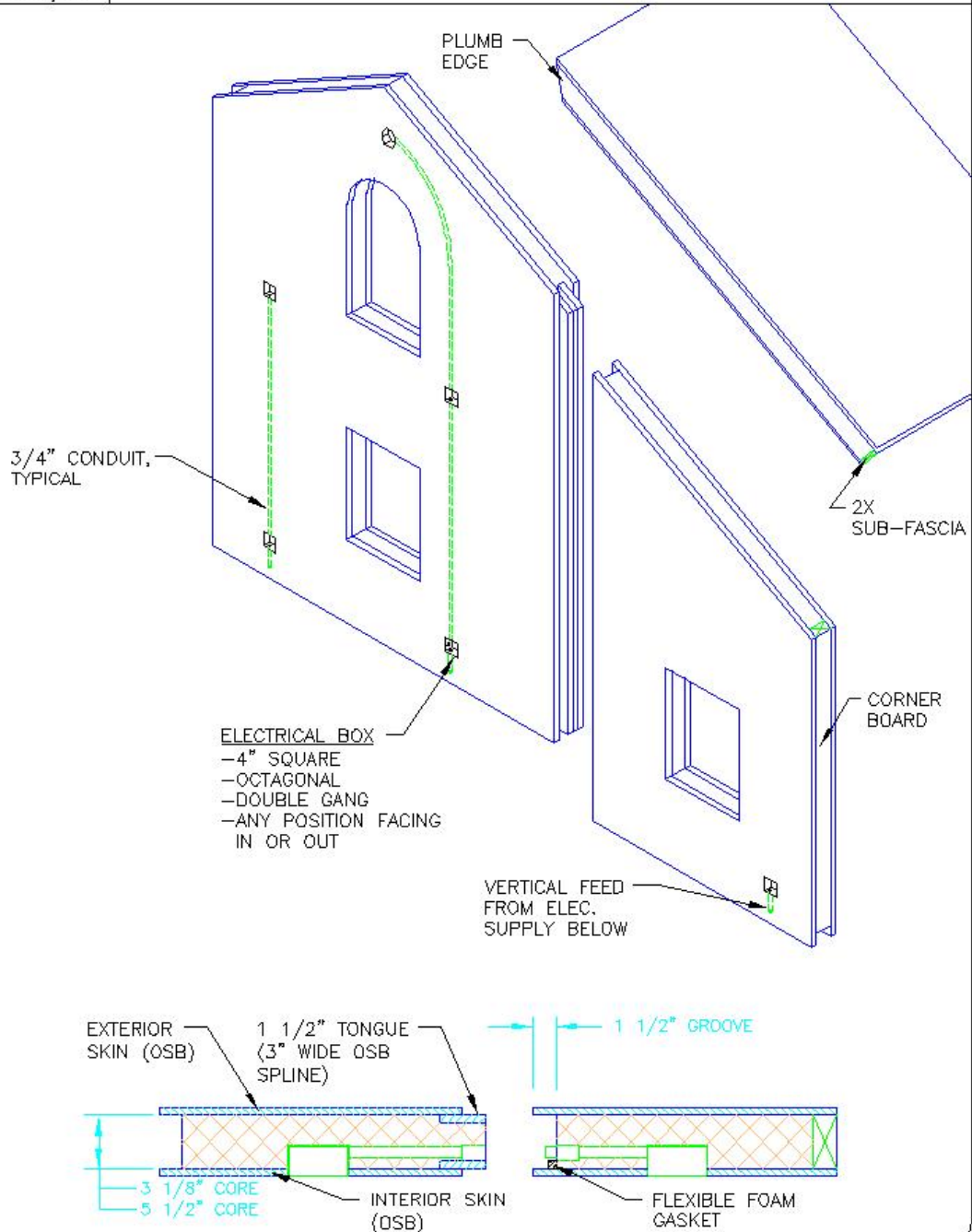

THERMOCORE ROOF GUIDELINES

It is not necessary to vent roofs placed directly on Thermocore's roof panels. Unlike traditional roofs that have an attic space that accumulates heat, homes built with Thermocore roof panels do not have an attic space to vent. Therefore the addition of roof vents is not required and shingle manufacturers like ELK shingles will honor a full warranty when their shingles are properly installed directly on top of Thermocore Panels. There are a few additional guidelines that should be considered when applying roofing materials over Thermocore Panels:

- Always use a thirty pound weight felt
- When using asphalt shingles as a final roofing material it is a good practice to place a strip of ice and water shield over the panel joints.(example Grace Water Shield). The strip should completely cover the panel joint. (approx. 6" wide strip) This material is available at most building centers.
- It is recommended to install a ridge vent at all ridges in your roof. The reason for this is the panel joint at the ridge of your roof is a butt joint and is the weakest of all the panel joints in your roof. Any movement in your structure could cause a crack in the joint allowing for air to pass through. As a safety measure it is a good practice to provide venting at the ridge and valleys of your roof. Eave venting is not necessary. (12/12 pitch roofs are the exception)
- When installing a metal roof over Thermocore Panels it is the best practice to cover the entire roof surface with ice and water shield.
- Keep indoor humidity levels below 50%.
- Incorporate the use of ceiling fans in vaulted roof areas.
- Incorporate an air to air exchanger or heat recovery ventilator as part of your HVAC system.
- Always protect panels from moisture prior to and after install. Install felt paper or ice and water shield following panel install.

Following these simple guidelines will help insure that your roofing material survives its full warranty lifetime.

1. GENERAL PANEL GUIDELINES

As with any building product there are a number of guidelines that should be followed when working with panels.

- A. Always protect panel foam edges from direct sunlight.
- B. Never allow OSB skins to rest directly on ground or concrete surfaces.
- C. Always have both panel skins (interior/exterior) bear on treated plate or sub-floor. (Structural applications only excludes timber frames)
- D. Always treat foundation and grounds for insects. (pre-treatment and annually)
- E. Exterior vapor barriers may be required by local code.
- F. Consult Thermocore before cutting any panel.
- G. Support roof panels every 10' or consult with Thermocore for design recommendations.*
- H. Always install an Air to Air exchanger or a Heat Recovery Ventilator along with your HVAC system.
- I. Keep indoor humidity levels at or below 50%.
- J. Always provide adequate support for panels when storing.
- K. Do not lift panels by top skin alone.
- L. Do not place plumbing in Thermocore Panels without consulting Thermocore.
- M. Do provide adequate bracing of panels during installation.
- N. All interior surfaces of Thermocore Panels must be finished with appropriate 15 minute thermal barrier. (1/2" gypsum board or 1"x wood paneling)
- O. Do follow all Thermocore fastening and bearing requirements during install.
- P. Do follow all manufacturers recommendations when installing interior and exterior finishes.

- Q. All panel screws require 1” minimum penetration into supports.
- R. Screws of equal strength may be used in place of nails or staples when used at equivalent spacing and frequency.
- S. Apply a 6” wide strip of ice and water shield or equivalent over all roof panel joints and valleys.
- T. For roof pitches other than 12/12, it is recommended to install a ridge vent system.**
- U. All Thermocore Panels are manufactured utilizing exposure 1 OSB skins. These skins are rated for minimum exposure to outside elements. It is recommended that all roofs be protected from exposure as soon as they are installed.
- V. Consult with Thermocore prior to moving or adding an electrical box or conduit.
- W. Follow all Thermocore Panel fastening procedures as outlined the Architectural Detail Binder or consult your Thermocore representative.

* Interior walls can be used for panel support

** Does not require eve vents. Consult your Thermocore Representative for details.

2. STRUCTURAL THEORY

Thermocore's Structural panels far surpass the strength of conventionally framed structures. Stress-skin panels are very strong when loaded axially (wall panel) because they perform as a composite column. The rigid foam steadies the relatively flexible skins over every square inch of their surface to prevent them from buckling. Figure 2A illustrates this effect.

Panels are also very strong in bending such as when a wall is under a wind load, or a roof panel is loaded with a heavy layer of snow. In bending, a panel behaves like an I-beam with very wide flanges and a web as thick as the panel is wide (Figure 2B). The skins act like the flanges by carrying the resultant compressive and tensile stresses. The core acts like the web by resisting shear forces and providing continuous support to the skins to prevent them from buckling and wrinkling. In special applications, Thermocore's injection process makes it possible to mold a variety of structural elements, such as laminated beams inside the panels for additional support.

FIGURE 2A & 2B

LOADING DETAILS

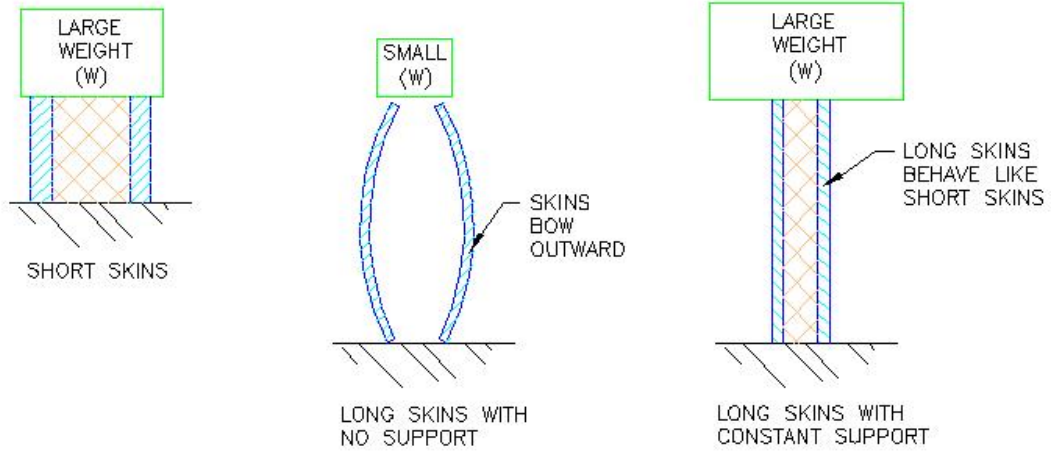

FIGURE 2A: AXIAL LOADING

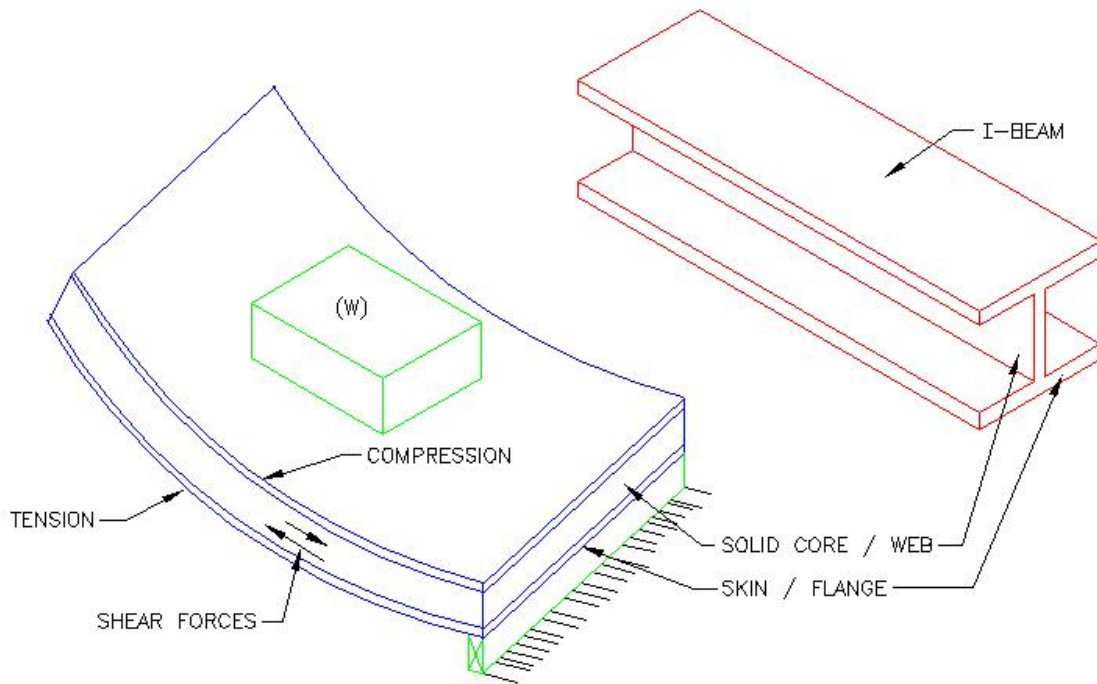

FIGURE 2B: TRANSVERSE (BENDING) LOADING

3. OFF-LOADING AND HANDLING PANELS ON SITE

Our panels will arrive at your job site on a semi-truck flatbed trailer typically 45' to 48' in length. Adequate access up to the home's foundation must be anticipated before arrival. It is the local builder's or homeowner's responsibility to ensure the panel truck can easily make the turn off the road onto the driveway and then successfully maneuver back to the home site. The builder or owner should be present at panel off-loading to ensure that any difficulties or panel damage due to inadequate access is the result of on site labor or conditions and not Thermocore. The trucks must be unloaded at the scheduled time of delivery. The trucking company does have a time limit for unloading. Any delay in loading may result in an additional shipping charge. Once the panel truck has pulled up to the foundation and subfloor, a crane and operator should already be in place to assist in off-loading the panel bundles. No fork truck is necessary. All panel bundles are eight foot wide by up to 24 feet long. Each bundle weighs up to 5000 pounds, thus a 25 to 35 ton crane is usually adequate for off-loading. See Table 1 for individual panel weights.

TABLE 1: Panel Weight (lbs per Square-Foot)

6-1/2" Roof panel	4.2 lbs/sq/ft
4-1/2" Wall Panel	3.6 lbs/sq/ft/
4-0" Wall panel	3.4 lbs/sq/ft

We suggest you unload bundles one at a time by sliding a 3"x8"x10' lifting timber (or equivalent) under each end of the bundle (See Figure 3). Connect each end of the lifting timbers with a sufficiently rated nylon strap to an overhead spreader bar attached to the crane ball. The crane can then off-load each bundle slowly while keeping it level. Make sure a flat cleared area on the ground is available for off-loading. We suggest panel bundles be placed as close as is feasible to the portion of the home to which they will be attached. All panels are numbered and by referring to the panel drawings, the installer can readily determine optimum bundle placement.

IT IS THE RESPONSIBILITY OF THE LOCAL INSTALLER OR BUILDER TO ENSURE THAT EACH PANEL BUNDLE IS SAFELY OFFLOADED AND PLACED ON A FLAT LEVEL SURFACE WITH NO TWIST OR BOW TO THE PANELS. ADEQUATE BLOCKING MUST BE PLACED UNDERNEATH ON 4' CENTERS. DO NOT STORE PANELS DIRECTLY ON THE GROUND. BE SURE THERE IS BLOCKING UNDER PANELS TO PROTECT FROM GROUND CONTACT.

Most panel packages can be off-loaded in about one hour and should then be covered with tarps to protect them from weather. Remember, if panels are allowed to get wet while bundled, mildew may result, panel edges may be soft and more easily damaged and panel edges may swell.

DANGER: NEVER ALLOW ANYONE TO WALK UNDER A PANEL OR PANEL BUNDLE WHEN BEING LIFTED BY A CRANE.



FIGURE 3

OFF LOADING PANEL BUNDLES

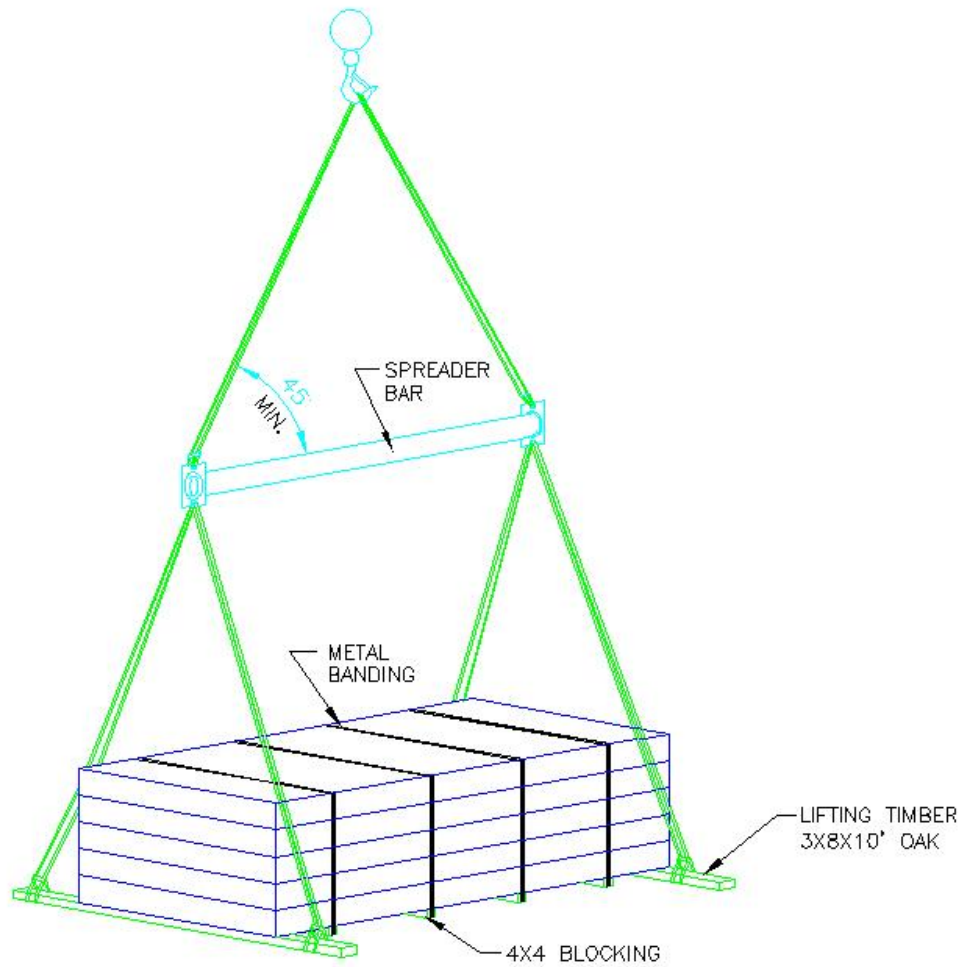

4. GENERAL INSTALLATION

The majority of our panels are placed within each bundle in the order they will be installed. Thus prep-time and manhandling of each panel is kept to a minimum. Typically wall panels are installed first followed by the roof panels.

Prior to the start of panel installation, the installer should thoroughly review the panel layout drawings, and stacking arrangement. The panel drawings show each panel number, rough opening size and placement, electrical box placements, conduit mapping, and panel installation notes. Pay particular attention to the wall panel overlaps at the corners (usually indicated on a plan view on first drawing page) to ensure the first corner panels are installed in the exact location for which they were built. Also, carefully read all notes which may indicate important starting or alignment positions, and places where insulated wiring must be pre-run or run during panel installation.

Tools typically needed for installation include general frame carpentry tools such as levels, chalk lines, plumb bobs, hammers, sledge hammers, extension ladders, 1/2" router, tape measures, drills with a 1 1/4" wood cutting bit, air compressor with air guns, chain saw, and a 16" panel saw or "Linear Link" chain saw for field trimming, and a grooving tool. While all Thermocore panels are pre-configured in our factory, some field cutting is generally required at hip and valley locations and where occasional foundation inaccuracies require field adjustment to a few wall and roof panels.

5. PANEL CONNECTIONS AND SEALING

Foam core panels perform two functions. The first is to provide a highly insulated shell around the building. The second is to provide a structural shell that withstands internal and external loads while providing openings for doors/windows and electrical hardware for wiring. These two functions cannot be achieved without proper connections between panels to prevent air infiltration and to provide structural support.

The goal in sealing all panel connections is to produce a thermal shell with virtually no air leaks. Then, fresh-air intake and stale-air exhaust can be completely controlled by mechanical systems such as an air-to-air heat exchanger. (See the Heating and Air Section).

A foam gasket is typically used to create a seal at all panel connections. The gasket consists of flexible foam with open cells that have been filled with a sealant material. When this gasket is compressed 50% or more, it provides a seal that prevents air infiltration. If the joint compressing the gasket expands or contracts, the gasket will move with the joint and always provide a seal.

The key to creating an air-tight thermal shell is to place all the gaskets in the SAME PLANE along the inner surface of the skins. Appendix A shows where the gaskets should be placed for a variety of panel connections. To use, simply peel back the self adhesive paper covering as the gasket tape is unrolled and stuck onto the appropriate surface.

All panel connections involve some type of fastener to attach the panels to themselves or to other structural elements. Panel screws are used to connect the panels together at corners or to attach the panels to timbers, trusses, and engineered-wood beams. The architectural details show the required panel screw length for different panel thicknesses, interior finish thicknesses, and type of wood. For all these scenarios, the screws should be installed on sixteen inch centers. Galvanized fasteners (1 1/2 inch long narrow crown staples 16 ga., 6" #8 screws, or 6 penny ring-shank nails) are used on a 6 inch center spacing to fasten the skins to 2x plates, and to fasten splines along the tongue and groove joints.

All gasket material, can foam, panel screws, and beveled 2x sill plates required for complete installation are included with every panel package.

6. WALL PANEL INSTALLATION

When wrapping a Timber Frame, Thermocore's eight foot wide structural wall panels can be designed to run either horizontally or vertically.

When building a stand alone structural panel wall, panels are generally installed with the long dimensions running horizontally for a ranch or two story home. This eight foot high wall allows a second floor system to be "platform framed" above using one of the two connection methods shown in Appendix A. A 1 1/2 story home with wall heights between 10' and 14' is generally "balloon framed" with the wall panels running vertically and the second floor system suspended between (see Appendix A).

The first step in wall panel installation is to prepare the floor system that the panel bottoms will be mounted to. The first sheet of every panel drawing package will usually provide a plan view of the wall system with overall dimensions and symbols showing how the panels overlap at corners. The floor system should be checked to these dimensions and adjusted if necessary. Next, if the panels set over a 2x plate, a chalk line should be snapped around the perimeter of the floor system to align one of the edges of the plate. This line should be located 1/2" in from the outside of the sub-floor to allow for barring of the exterior skin and placement of the foam gasket. The pre-sized and beveled plates (provided with the panel package) should then be nailed to the sub-floor using 16 penny nails, 12 inches on center and through every floor joist. When installing the pre-sized plate pay close attention to the corner overlap details shown on the plan view in the panel drawings. Be sure when laying the plate for a wall that is "overlapped" to leave a 1/2" space between the two plates for the OSB on the adjacent panel. A strip of 1/2"x1/2" gasket tape can be installed on top of the floor against the outside edge of the 2x plate for top and slab mount systems or on top of the treated sill plate for side mount systems.

Once the panel bundles have been unbanded, the top panel is generally the first to be installed with each panel beneath the next in line. Panels may not always be stacked in order due to loading requirements when it applies to shipping. Wall panels are usually installed from one corner of a wall section to the other. However, specialized wall panels may need to be installed first such as when a large arched opening fits very tightly between timber posts. The wall sections are usually installed in an order that permits the last panel of a corner to overlap the previous wall section. NOTE: it may be necessary to clean the groove at the bottom of wall panels to insure proper barring of skins on sub-floor.

When wrapping a Timber Frame, chalk lines should be marked on the exterior OSB skin at the centerline location of all timbers. Before the panel is moved, panel screws provided by Thermocore should be hammered through the OSB and foam core along the chalklines every sixteen inches. Next, 1/2" x 1/2" gasket tape should be installed along the top of the tongue against the edge of the inner skin. (gasket may be placed on inner groove surface)

The panel is now ready to be rigged for lifting with a crane. Appendix B shows various methods for rigging panels. While the panel is being rigged, the panel drawing should be checked to determine if an electrical access hole is required between the bottom or side of the panel and the floor system (See Appendix A). If the panel mounts on top of the floor system, a measurement between the panel edge and actual exit point of the conduit should be transferred to the 2x plate. Then a 1 1/2"

hole is drilled through the plate into the floor cavity. If the panel mounts against the side of the floor system, the panel will feature a 4x4 electrical box centered over the height of the band joists. The position of this box from the panel edge can be read off the panel drawing and then transferred to the side of the band joist. A 4"x4" hole must then be cut into the side of the floor joist so the 4x4 electrical boxes can be used as an access port for wiring.

Once the panel is attached to the crane (don't forget to attach a tow line if it is windy), the panel is lifted and positioned about 4 feet above floor. At this point (for top mount systems only) a 12" long section of 3/4" flexible conduit is inserted into any conduit couplings exiting the bottom of the panel. Next, the panel is slowly lowered into place making sure any conduit stubs are guided through the 2x plate. While the panel is being lowered, the tongue or groove edge can be inserted into the edge of the previously installed panel. Once the panel is at the correct vertical position, it is leveled, shimmed if necessary, and aligned correctly with any mating corner post or structural corner panel.

If the panel is mating with a previous panel, the tongue and groove connection must be driven completely together for a foam-to-foam joint. The OSB edges should be close to 1/4" apart or less and the gasket compressed. If any portions of the gasket come loose or are damaged, new gasket material can be squeezed between OSB edges to ensure a good seal. Appendix C illustrates a ratcheting tool with special teeth that can penetrate the outside OSB skins across a panel joint and pull the joint together. Two of these tools, one at each end of the joint, should be used at every panel connection.

7. ROOF PANEL INSTALLATION

When installing Thermocore panels over a Timber Frame roof system, the long dimension of each panel is run horizontally from gable end to gable end. On a Common Rafter roof, the eight foot panel's widths are designed to break over timbers (except for roof overhangs). On Principle Rafter/Common Purlin roof systems, the long edge of each panel should break over a purlin. If the Timber Frame cannot be designed to accommodate these panel breaks, the long dimension of the panels are run vertically from eave to ridge. Refer to your roof panel layout drawings for exact roof panel placement. In either case, roof panels are preconfigured to the exact shape and size needed with all subfacia boards, electric boxes, conduit, tongue and groove connections, and skylight blocking already preinstalled. (Some field cutting is commonly required at hip and valley joints.)

When installing Thermocore Structural panels as a roof system supported by simple ridges and major purlins of engineered wood products, all panels are run eave to ridge. As shown in the architectural details, exterior wall panels contain a top plate molded-in at the roof pitch. Roof panels are lowered onto wall panels and structural ridge and purlins (where necessary) and are attached with panel screws. Thus, when prepping each roof panel, chalk lines should be used to locate all screwing surfaces on the exterior skin. Then panel screws should be driven through the exterior skin every sixteen inches on center. On steeper pitched roofs it is prudent to attach 2x walk boards to each panel before flying to the roof. Pay particular attention when driving panel screws to prevent the fastener from missing its destination and showing through to the inside of the building.

Foam gaskets should also be applied to the top of the tongues before flying to the roof and along the inside edge of the groove. Special attention should be given to the gasket seals between tongue and groove joints that overhang the walls along the gables and eaves. Here additional gasket must be applied across the tongue and along the bottom of the tongue spline up to where it meets the wall panel. (See roof connection details) Also, ensure that a gasket has been applied to the top of the wall panels along the exterior skin and is sufficiently compressed by the roof panel. If the gasket was knocked off, damaged, or not sufficiently compressed, additional gasket should be inserted.

Roof panel connections at the ridge and some valley and hip joints require particular attention. While all Thermocore panels are preshaped to the exact size needed on the home, some allowances must be made for inaccuracies due to the work of others. For this reason a small gap is anticipated between panels at the ridge, valleys, and some hips. ½"x1" foam gasket tape is supplied for these areas as are cans of spray foam sealant. The sealing of these areas should be the last operation performed on the roof by the panel installer.

Roof panels are generally rigged so they will "fly" at the pitch of the roof. See Appendix B for specific rigging techniques. When flying roof panels that are run eave to ridge, a three point strap attachment (two at eave, one towards ridge) is usually adequate for panels 8' x 16' and smaller. Panels larger than this require an additional attachment (four point) towards the ridge. The same number of attachment points should be used for roof panels that run in the horizontal direction.

After installing the roof panels they should be covered immediately to avoid getting wet. Any moisture that is allowed to get on the roof panels can cause damage to the panels.

8. DOOR AND WINDOW OPENINGS

Thermocore is the first U.S. foam core panel manufacturer that builds a pre-configured panel with door and window blocking pre-installed prior to foam injection. In many cases, depending on each panels' ability to withstand shipping stresses; the inner and outer skins have been trimmed and removed at door and window locations. This means that no field labor is required before actual doors and windows can be installed conventionally. To protect some panels during shipping, the interior skin and sometimes the outer skin will need to be trimmed on site after installation of the panel. All trimming can be accomplished by one man from the inside of the structure in a minute or two per opening.

While skylights are generally discouraged for maintenance and energy loss considerations, roof panels can be shipped with skylight openings blocked and partially trimmed. Once all panels have been installed, conventional door and window installation can proceed.

9. WIRING INSTALLATION

All Thermocore wall panels are built with 4x4x2 plastic electric boxes connected by 3/4 inch conduit installed per plan. Conduit is run both horizontally and vertically as is needed with locations mapped in the panel layout drawings (See cover and Figure 1). Other types of electrical boxes commonly used include 4" octagonal boxes for light fixtures and multiple gang boxes for switch locations. When installing wall panels it is the installer's responsibility to ensure that each horizontal conduit stub is guided into the corresponding conduit coupling mounted in the previous wall panel along the tongue and groove joint. Vertical conduit is extended into the first floor system first by on site drilling of the 2x4 bottom plate into the joist cavity. Then a 10" conduit extension is installed in the coupling mounted on the underside of the wall panel. This enables the electrician to run a home run in electrical wire up into the first electric box in each wall before switching to single stranded wire conductors. Each electric box provides 32 cubic inches of make-up space enabling several wire junctions to occur in addition to one or two duplex receptacles. All 4x4 electric boxes can be reduced to a single gang receptacle opening by the use of a trim ring. All rough in wiring should be done after wall panel installation.

Thermocore roof panels are also built using the same types of electrical hardware. In this case, octagonal boxes are usually connected with 3/4" conduit to access boxes (4x4) which have been conveniently located over a future partition wall or wall panel conduit chase for wire access. It is easier to pre-run electrical wire between the fixture and wire access drops as the roof panels are installed. NOTE: It is recommended to pre-run electrical wire between wall and roof connections as roof panels are being set.

If a ceiling fan is going to be mounted directly to the roof panel, 2x6 blocking is provided behind the octagonal box for structural attachment of the fan. This type of box will be shown on the roof panel drawings using a fan symbol. **NEVER INSTALL A CEILING FAN FROM A BOX THAT HAS NOT BEEN REINFORCED WITH 2X BLOCKING.**

Conduit and boxes are provided in panels by Thermocore to eliminate field labor and inflated electric installation costs due to unfamiliarity with this building system. Wiring exterior wall and roof panels can actually be quicker than conventional installations.

10. PLUMBING INSTALLATION

Good plumbing practice does not allow water or drain lines to be located in exterior insulated walls, thus your plumbing contractor should have little difficulty in working with a foam core panel house. Exterior hose bibs can be run through the rim joist. Sinks and vanities along an outside wall can have supply and waste lines exit through the floor or a side partition wall. Second floor plumbing in a Timber Framed home can be run through built up joist cavities or through vertical chases hidden in first floor walls and closets. Once the mechanical contractors have completed their rough ins, all penetrations made through the foam core panel envelope should be thoroughly sealed. To avoid massive heat loss and water condensation damage, all roof vents, gas flues, fan exhausts, etc., should be sealed with high quality caulking and urethane spray foam sealant.

11. HEATING AND AIR INSTALLATION

HVAC supply lines and cold air returns should only be located in interior floor and partition wall systems. No ductwork in the exterior wall and roof systems should be contemplated. While all supply lines should be sized for good air flow, the heating unit can be dramatically downsized because of the reduced heating load found in foam core panel housing. Typically, heating loads in averaged sized Thermocore panel homes can be 25,000 BTU per hour. In addition, because of the thermal properties of foam core walls and roofs, temperature differentials between floor and ceiling and room to room are significantly smaller. Thus it is not always necessary to place registers under windows to wash the cold exterior walls with heat to avoid drafts. Simpler, shorter, and more centrally located supply lines can help control HVAC costs.

Due to the tight construction achieved by the use of Thermocore Panels, the installation of an air to air exchanger or heat recovery ventilator (HRV) is a condition of Thermocore Panels warranty. All homes that utilize Thermocore wall and roof panels must install a fresh air system.

12. SPECIAL CUTTING AND ROUTING OF PANELS

Occasionally a homeowner decides to add a window or door or skylight after panel installation. This necessitates field cutting of the panel and routing back the foam 1 1/2 inches to accept 2x inset blocking. The first step is to mark the exact rough opening size of the door or window on the interior of the panel skin. The use of a level and framing square can be important aids. Next, cut along the layout lines with a power saw, (preferably a 14" or 16" Makita beam saw), and finish with a reciprocating saw or small chain saw if necessary. Once you have checked the cut edges of both panel skins for squareness, you are ready to route the foam back 1 1/2 inches around the cut opening. This task can be accomplished by using a special grinder fitted with a foam routing bit. Also a carpentry router can be fitted with a large table and a straight bit, and set to a 1 1/2 inch depth for multiple passes. A third low tech alternative involves driving several nails through a board so that they protrude 1 1/2". Then use the nails to dig out the foam by running the board back and forth along the cut opening. Do not use a hot wire cutter with polyurethane foam. Once the foam has been removed a 2x4 or 2x6 can be inset into the channel created between the panel skins and nailed off. It is recommended that a bead of spray foam, sealant, or gasket tape be inserted between the 2x and the urethane foam core prior to installation.

If an electrical box must be added to a panel wall, the opening is marked and cut out with a router to the depth of the electrical box. The router can then be used to create a channel for a wire to run. NOTE: Never cut a horizontal channel that runs more than half way across a panel. Failure to follow this guideline can cause structural failure.

Other cutting such as trimming roof panels to fit at valley or ridge areas can generally be done with a large power or chain saw. Refer to your panel layout drawings for specifics on panel trimming.

13. FINISHING

For foam core panel wraps around timber frames, either of two wall finishes options are commonly used. The first procedure involves applying 5/8 inch plywood spacers to the exterior of the frame and then installing structural OSB/OSB panels. This creates a gap between the frame and panels. 1/2 inch drywall can then be glued, slid behind timbers, and screwed to the OSB panel skins at a later time after the home is weather tight.

There are also two options for installing roof panels over Timber Frames. 1"x8" knotty pine or aspen tongue and groove boards may be applied above the roof timbers prior to panel installation thus eliminating all finishing. A second less popular option involves the application of drywall to the topside of either roof timbers or the panels prior to installation. The drywall board must then be screwed into the panels from beneath and these screw heads finished prior to painting. For those wall applications where drywall is field applied, the use of a plaster or trim ring is required on all panel electric boxes. This trim ring should have a 1/2" bumpout to allow for the drywall thickness and can also reduce the opening from a two gang to a typical single gang device.

Structural wall and roof systems require the application of electric box trim rings and drywall hanging and finishing after the roof is on and during the typical drywall phase of construction.

Structural wall panels allow for typical wall hung cabinet installations. Structural wall panels easily support baseboard, curtain rod, and picture frame attachments.

All types of exterior wall finishes can be applied to Thermocore wall panels including cedar, vinyl, brick, and stone sidings. Manufacturers associations for the chosen siding type can be checked for recommendations as to siding applications, nailing schedules, paper sheathing coverings, etc. For instance, wood sheathing such as OSB should have a waterproof covering, such as Tyvek before exterior finishes are attached. Also some cedar siding suppliers recommend their siding be applied to 1"x3" battens previously screwed to the wall panels to allow for drying and ventilation on the backside of the wood siding.

Once panel installation is complete, any openings with panel skins still attached should be removed. A special router bit designed for this purpose is provided with each package. This bit will run along the 2x blocked opening while removing the OSB skin very quickly. Next, all doors and windows can be installed by local personnel just as they would be on a conventional home. Then siding applicators should begin their work.

Roof trim, ice & snow shield, and drip edge may be applied according to the manufacturer's recommendations. We recommend a more permanent roofing system such as metal, slate, or tile. If you must use asphalt/fiberglass shingles, you may opt for an air space with eve and ridge vents. The air space is commonly created by running 1"x3" battens eve to ridge 16" O.C. and covering with 1/2" thick plywood or OSB sheathing. If fiberglass shingles are applied directly to the roof panels, a layer of ice and snow shield should be applied over the entire roof surface and covered with 300 pound or greater shingles. Fiberglass shingles applied directly to roof panels is called a "hot roof" and is not guaranteed by all shingle manufacturers.

14. CLOSING

Thermocore has endeavored to produce a user friendly panel system which eliminates many of the problems found in more antiquated framing and panel styles. We stand behind our work by providing a written limited lifetime warranty with each package. We are always available to answer questions regarding the installation and finishing of our panels. We offer either an onsite advisor to train your local crew in panel installation or we can provide our own installation crew. Our commitment to minimal fuss in panel installation and maximum durability of the structure is an evolutionary process and will continue into the future.

Thank you for choosing Thermocore Panel wall and roof systems